

BLUE STAR ANTENNAS

1.25CM-4EL

INSTRUCTIONS AND USE

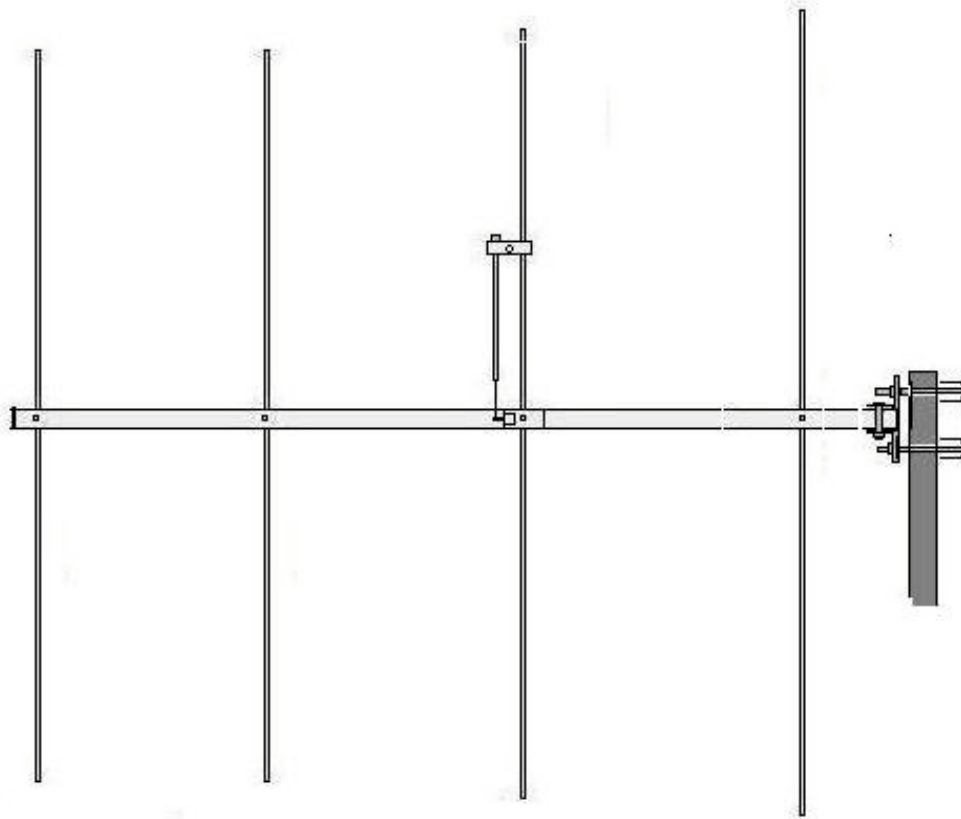

**"This Antenna conducts electricity Keep away from Power lines"
All ways use safe instillation practices, do not install any antenna on a mast
or tower with in 1 and $\frac{1}{2}$ times the falling distance to any electrical lines!**

Location of the antenna is very important.

Surrounding objects such as trees, power lines, other antennas, etc. will seriously reduce efficiency. To minimize the effects of surrounding objects, mount the antenna as high and in the clear as possible. If metal guy wires are used, they should be

Tuning your Antenna for Best Results

If you wish to check the VSWR before installation,

Please observe the following procedures, for the best results.

Temporarily mount the antenna with the boom vertical, reflector at least one foot (30 cm) above ground on a non-metallic support, to prevent detuning the antenna. Guy the top of the boom if necessary to prevent it from falling over. Do not use line with wire in it.

- Keep other antennas; metal objects and guy lines clear of the antenna under test.
- Do not attempt to tune the Yagi near the ground with the boom parallel to the ground since ground effects will nullify any adjustment and poor performance may result.
- Run the coax cable from your transmitter to the area in which the antenna is going to be tested. The length of this cable or your feedline is not critical.

1. Connect a good quality SWR bridge to the end of this cable.
2. Connect a short length of cable 10 ft or less from the SWR Bridge to the antenna.
3. Set the transmitter to your center operating frequency.
4. When you read SWR, be sure you move far enough away from the antenna so that your body does not effect the reading.
5. Measure the SWR.

1. If it is high, move the Shorting Bar and/or Tube by 1/4" (.6 cm) in one direction and check the SWR.
2. If the SWR improved, then continue moving the Shorting Bar and/or Tube in the same direction.

6. If the VSWR deteriorated then move the Shorting Bar and/or Tube in the opposite direction.

1. Repeat this procedure until no further improvement can be made.

You have matched your antenna to 50 Ohms. Then tighten all connections. Tape the feedline to the boom and mast.

PLAN YOUR INSTALLATION CAREFULLY.

If you use volunteer helpers be sure that they are qualified to assist you.

Make certain that everyone involved understands that you are in charge and that they must follow your instructions.

If you have any doubts at all seek a professional antenna installation company to install your antenna.

WARNING

YOU MUST INSURE THAT NEITHER PEOPLE NOR PETS CAN COME IN CONTACT WITH YOUR ANTENNA WHILE IT IS IN OPERATION OR WHILE TUNING. DEADLY VOLTAGES AND CURRENTS MAY EXIST.

SINCE THE EFFECTS OF EXPOSURE TO RF ARE NOT FULLY UNDERSTOOD, LONG TERM EXPOSURE TO INTENSE RF FIELDS IS NOT RECOMMENDED.

DO NOT AIM OR POINT THE ANTENNA AT ANY PERSON OR ANIMAL WHILE IT IS IN OPERATION OR WHILE TUNING.

ALWAYS OBSERVE PROPER RF SAFETY AT ALL TIMES.

THIS ANTENNA IS AN ELECTRICAL CONDUCTOR. CONTACT WITH POWER LINES CAN RESULT IN DEATH, OR SERIOUS INJURY.

DO NOT INSTALL THIS ANTENNA WHERE THERE IS ANY POSSIBILITY OF CONTACT WITH OR HIGH VOLTAGE FROM POWER CABLES OR SERVICE DROPS TO BUILDINGS.

THE ANTENNA, SUPPORTING MAST AND/OR TOWER MUST NOT BE CLOSE TO ANY POWER LINES DURING INSTALLATION,

REMOVAL OR IN THE EVENT PART OF THE SYSTEM SHOULD ACCIDENTALLY FALL.

FOLLOW THE GUIDELINES FOR ANTENNA INSTALLATIONS RECOMMENDED BY THE U.S. CONSUMER PRODUCT SAFETY COMMISSION.

POLARIZATION

You must decide on a mounting position.

Your Element YAGI allows for mounting in, Vertical or Horizontal Polarization.

FEEDLINE

Pay close attention to the feedline you use at VHF frequencies. Much of the regular RG-8X coax has too much loss at VHF frequencies RG-58/U lengths over 50 ft is usually not recommended. Any gain realized from the antenna could easily be lost with poor coax.

RG-213 or 9913 is Recommended.

IMPORTANT

Take all of the $\frac{1}{4}$ " Round elements and screw in one of the 4-40 x3/4" Stainless Steel screws in to the center of each element. This is to make sure all the elements are threaded properly and that the screws start easily. Lay out the elements according to size. The dimensions and position of all the elements are shown. Attach all the elements to the boom as shown.

CAUTION

Do NOT over tighten the screws this will bend the elements. Turn the screw until its just snug and then $\frac{1}{4}$ turn more

Trouble Shooting High SWR

Test the SWR with a good UHF SWR Meter and HF meter will show higher than real SWR.

Replace the antenna with a 50-OHM dummy load.

If the swr is greater than 1:1 Replace the coax or connectors and test again.

Blue Star Antennas

Assumes no responsibility for injury or damage,
Resulting from the use or instillation of this antenna!

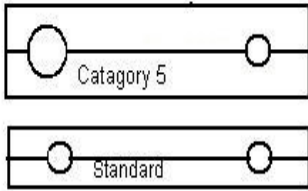

Shorting Bar depending on model

Adjust Gamma Match as necessary to attain the lowest SWR. A good starting place is from the center of the feed to the shorting bar 3 1/2 inches. Adjust the tube as needed. If mounting Vertical Place as pictured Gamma Assembly up.

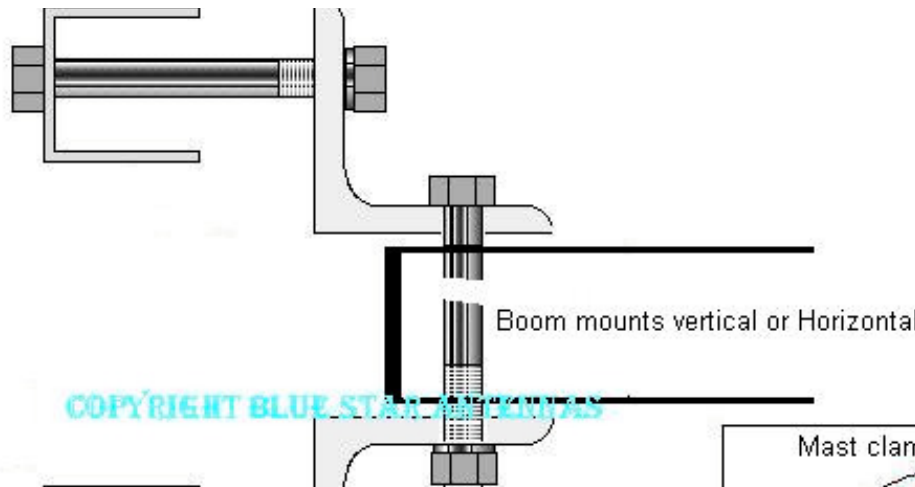
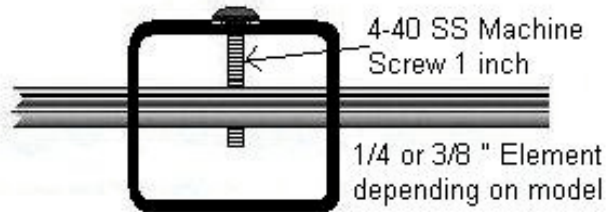
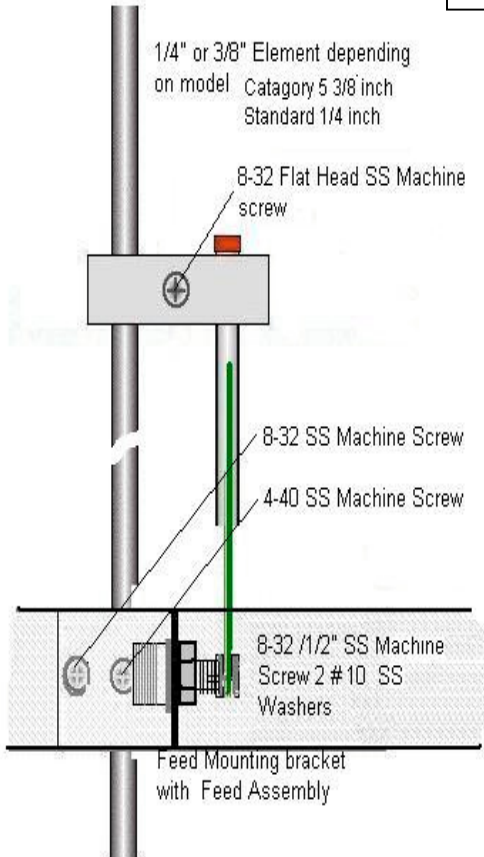

COPYRIGHT BLUE STAR ANTENNAS

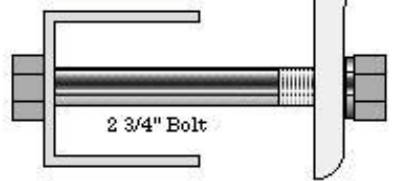
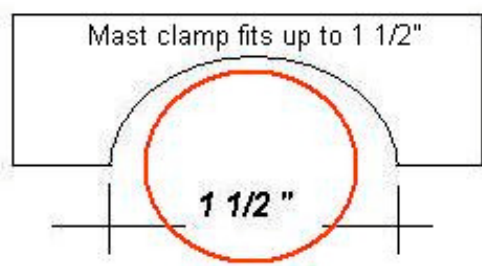

MMANA-GAL v. 1.1.0.10
220-4el Blue Star Antennas

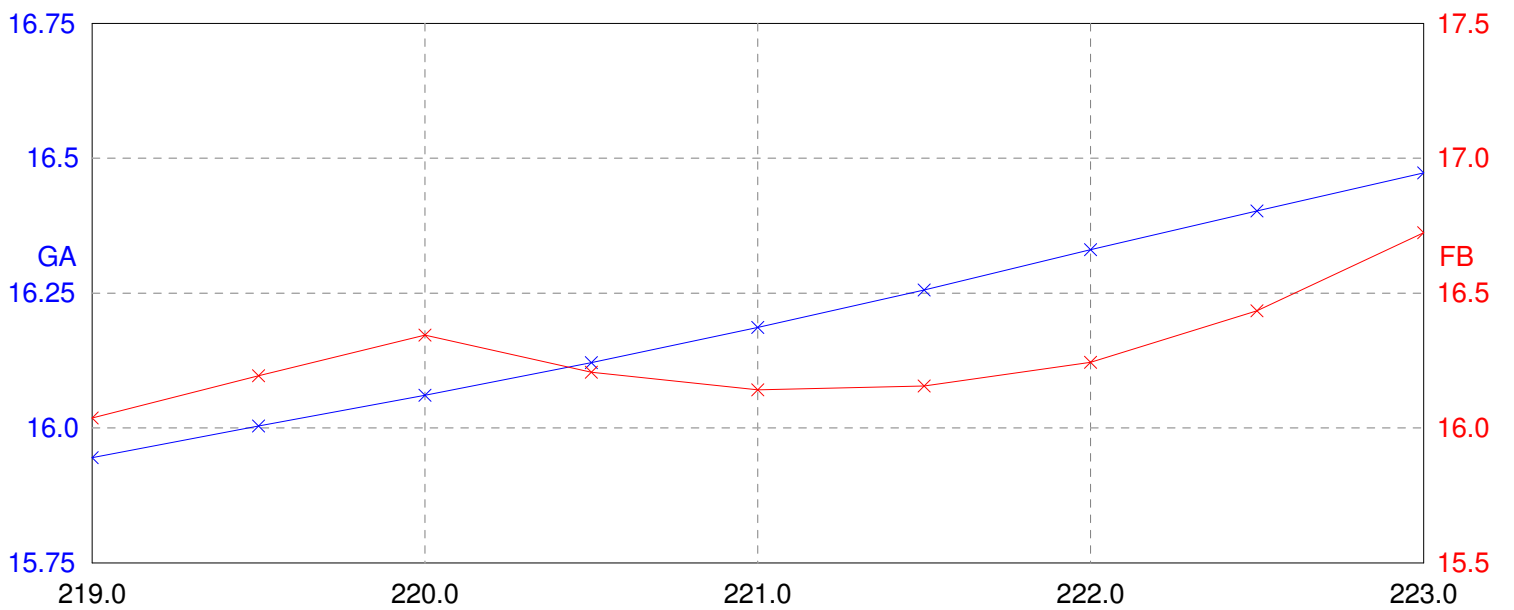
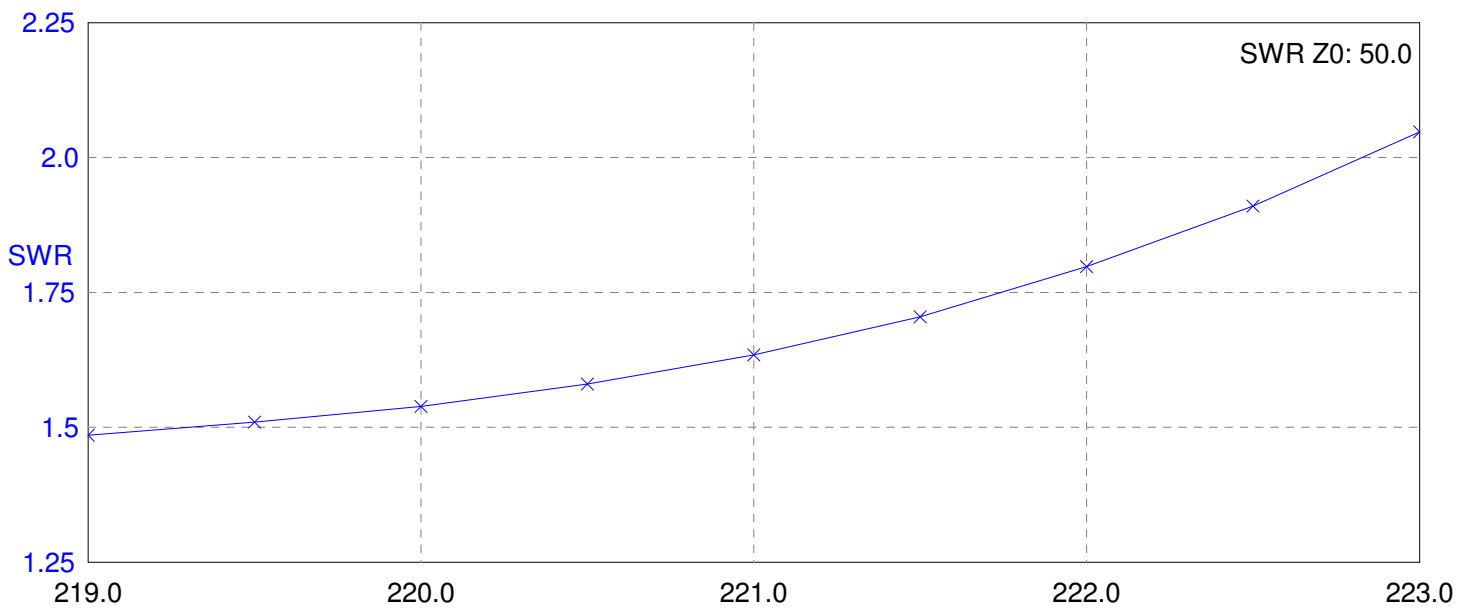
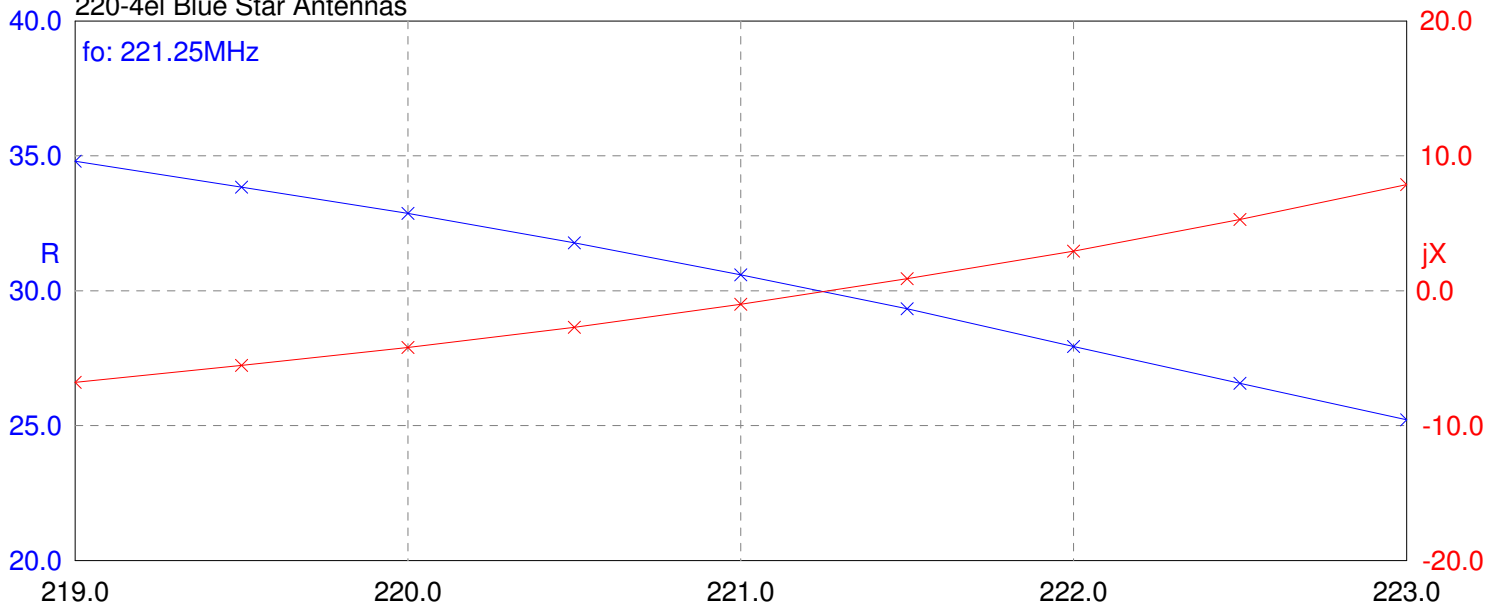

MMANA-GAL v. 1.1.0.10

220-4el Blue Star Antennas

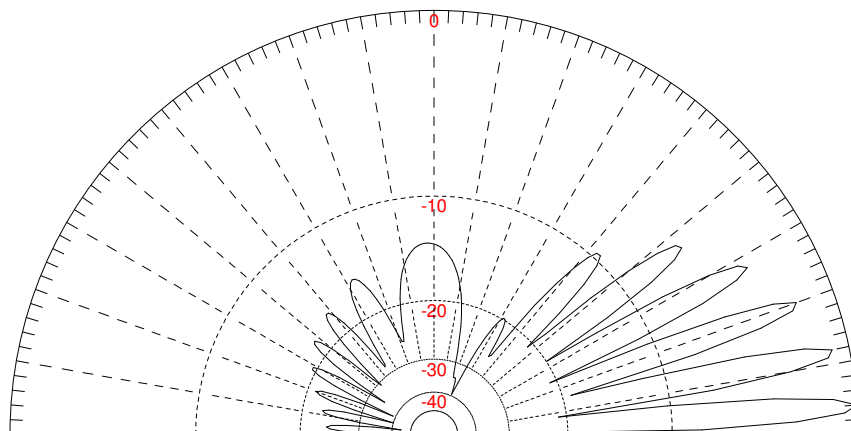
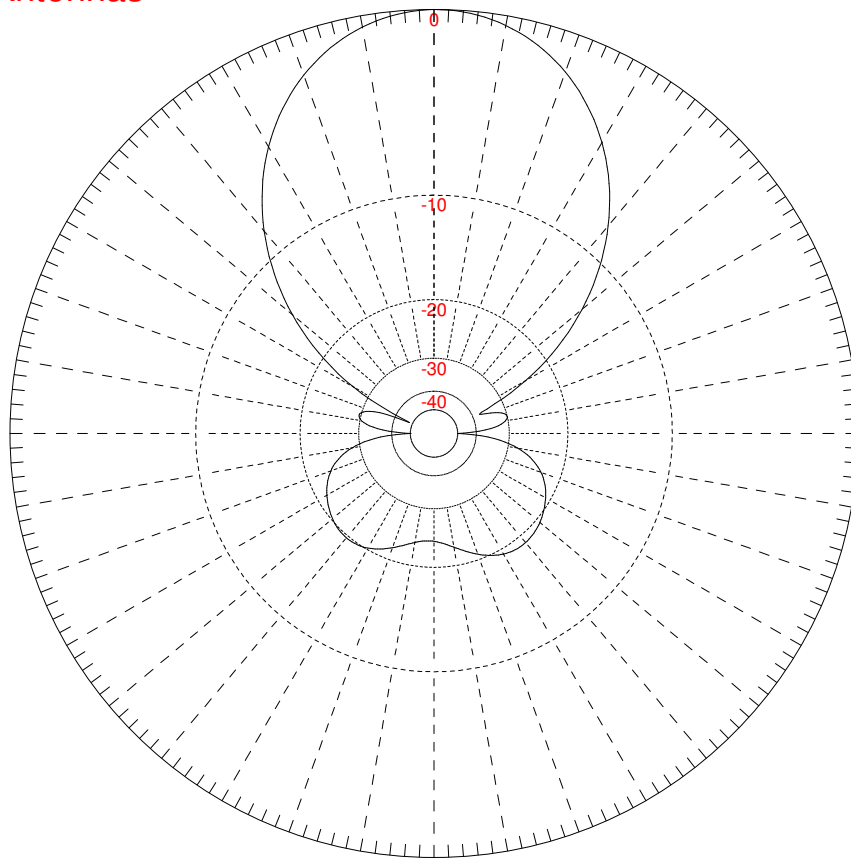

Ga : 16.19 dBi = 0 dB (Horizontal polarization)
F/B: 16.14 dB; Rear: Azim. 120 dg, Elev. 60 dg
Freq: 221.000 MHz
Z: 30.603 - j0.988 Ohm
SWR: 1.6 (50.0 Ohm), 19.6 (600 Ohm)
Elev: 3.8 dg (Real GND :5.00 m height)