

BLUE STAR ANTENNAS  
RED CROSS FREQUENT YAGI  
RC-4EL  
INSTRUCTIONS AND USE

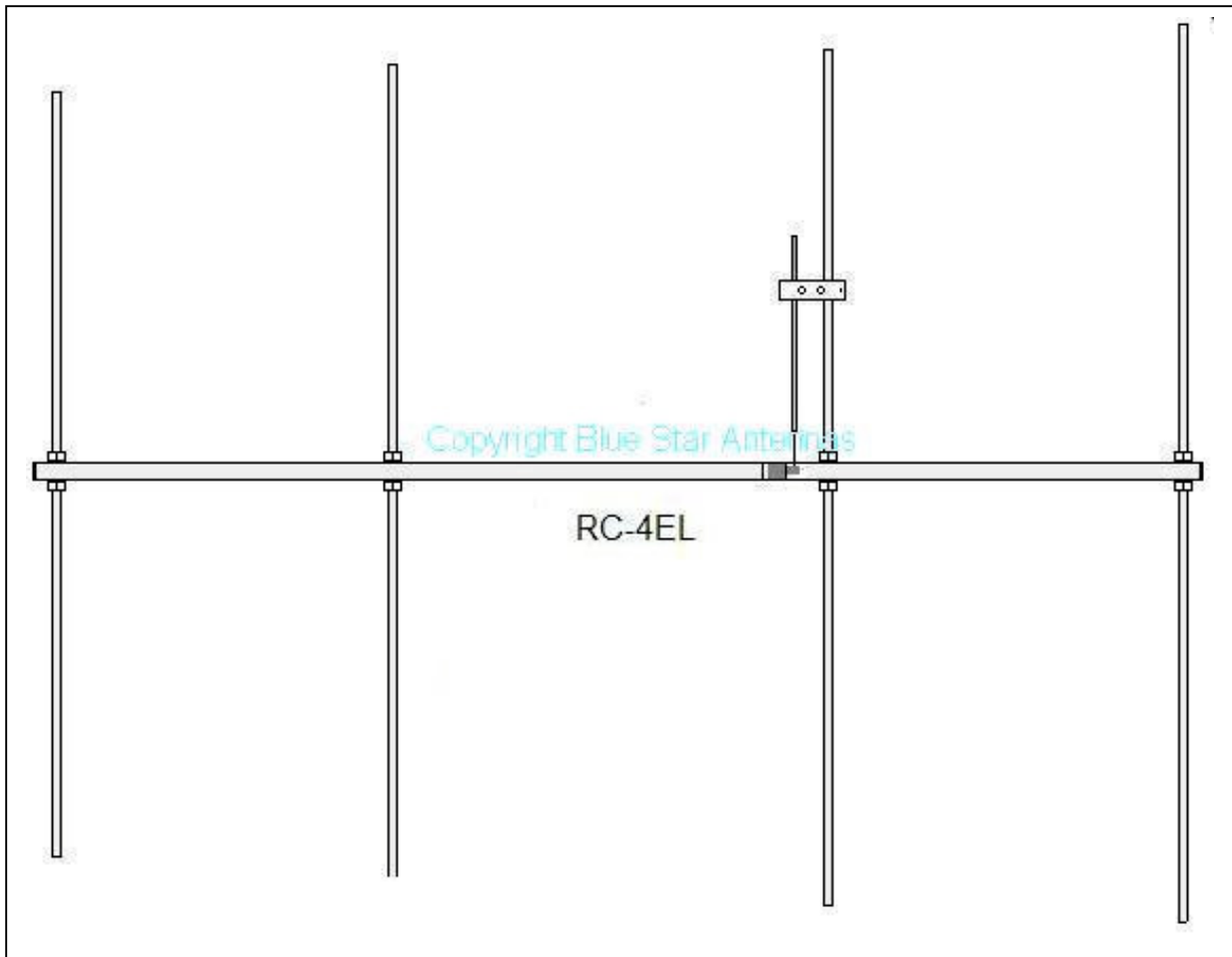

**"This Antenna conducts electricity Keep away from Power lines"  
All ways use safe instillation practices, do not install any antenna on a mast  
or tower with in 1 and  $\frac{1}{2}$  times the falling distance to any electrical lines!**

Your Element YAGI allows for mounting in, Vertical or Horizontal Polarization.

## POLARIZATION

You must decide on a mounting position. Prior to assembling the boom.

## FEEDLINE

We recommend you use the best quality feed line possible. This will allow the best possible performance

Assemble the boom As pictured

## IMPORTANT

Do not remove the red plastic retainers until you install an element in the opposing hole!

- Lay out the element in pairs according to size.
- Screw 1 of the element pairs into proper hole in the boom.
- **Be careful not to cross thread the element.**
- Remove the red plastic retainer and install the opposing element.
- Tighten with 2 - 9/16 wrenches
- **Do not over tighten and strip the threads.**
- Repeat for each set of elements.
- Attach the Feed angle to the boom with the 8-32 SS Screws.
- Assemble the Gamma Feed as pictured.

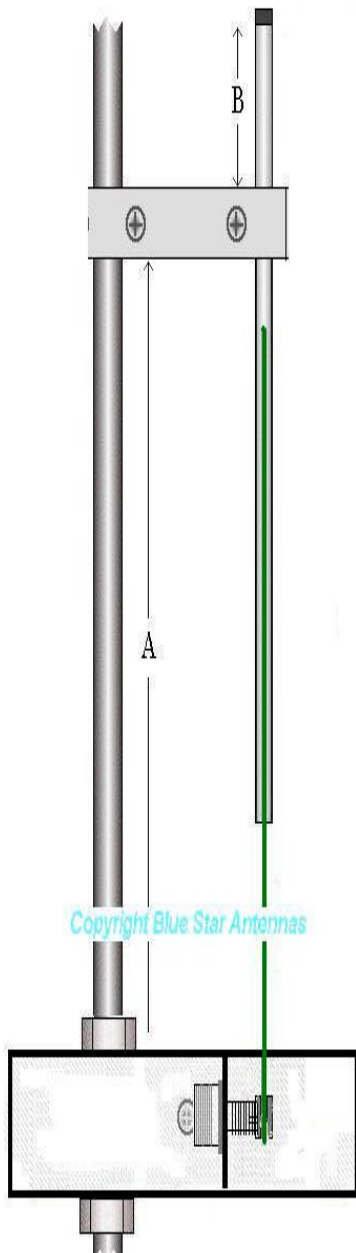

Center Frequency	A	B
46-47	12 1/2"	7 1/2"
50-51	22"	0"

The lengths of "A" & "B" should be what ever it takes to get the lowest SWR. On the portion of the band you plan to work. Tune the antenna aprox 5-6 ft off the ground, away from metal objects. SWR usually goes doe even more when the antenna is elevated.

A & B both affect SWR  
 A effects the frequency  
 B Affects the SWR

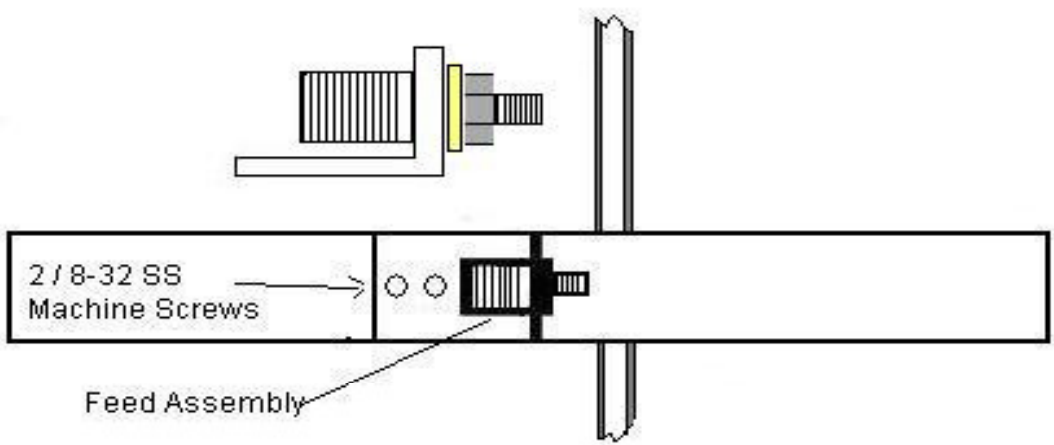
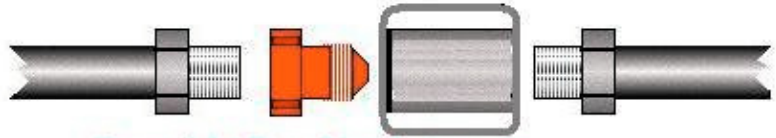

# Boom Splice

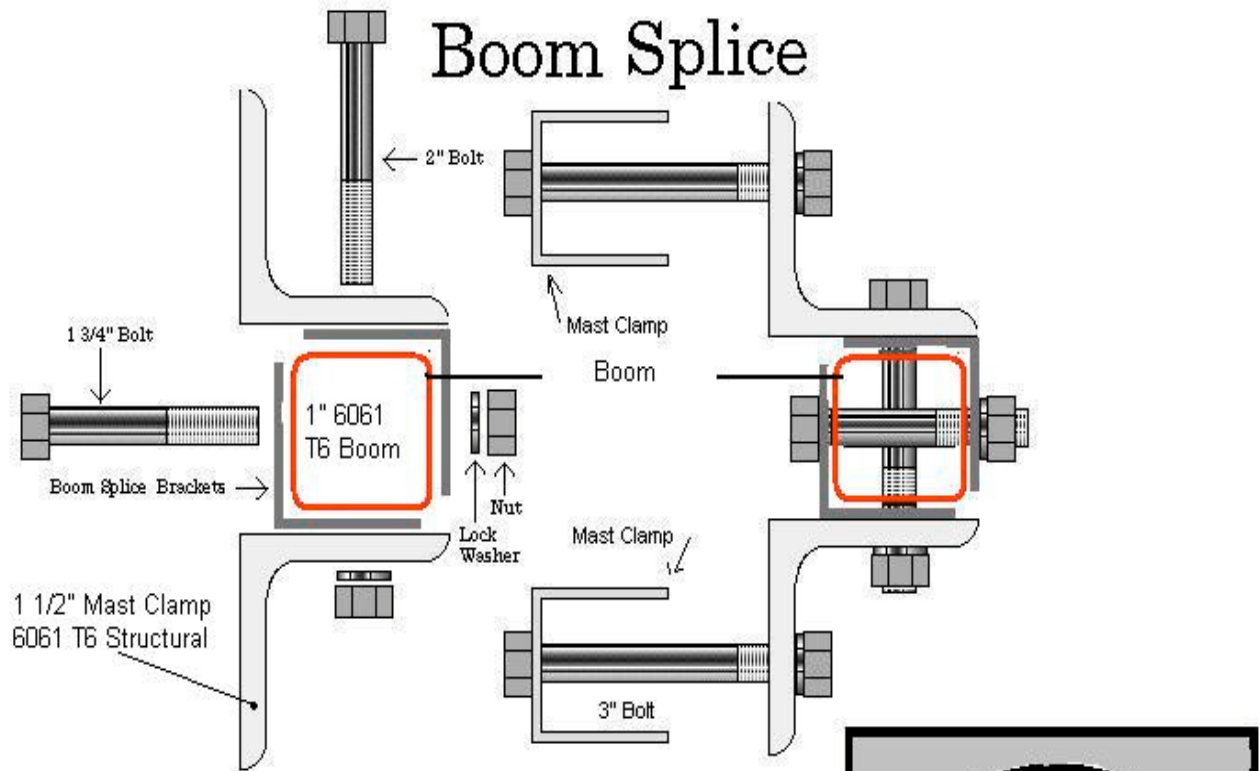

Copyright Blue Star Antennas

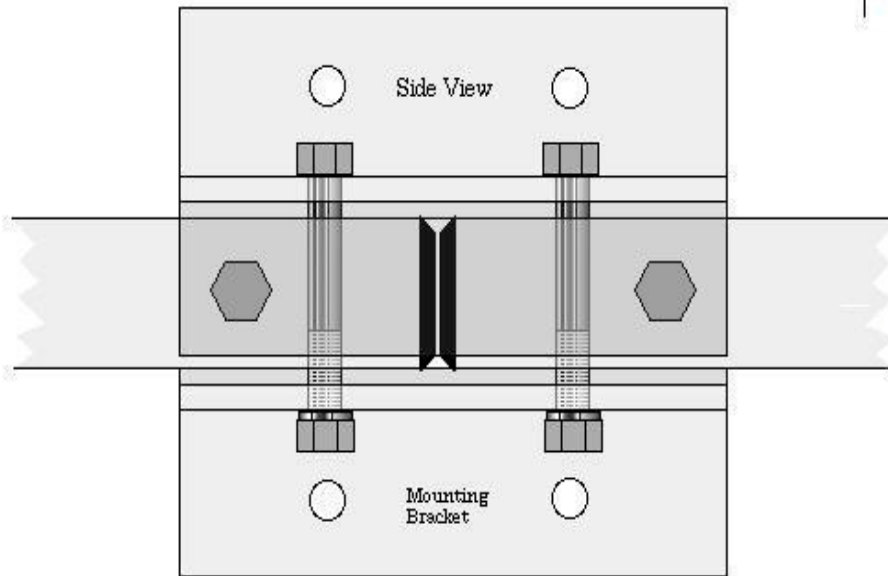
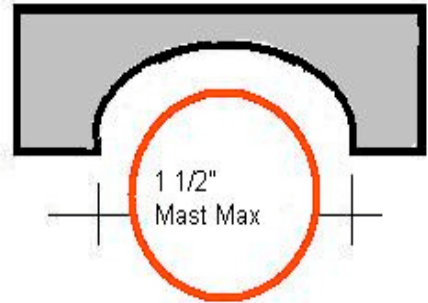

47.5 Red Cross 4 Element Yagi Blue Star Antennas

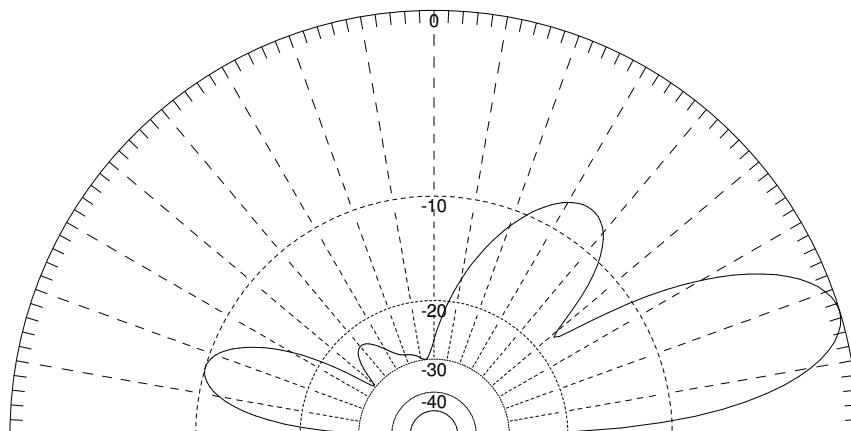
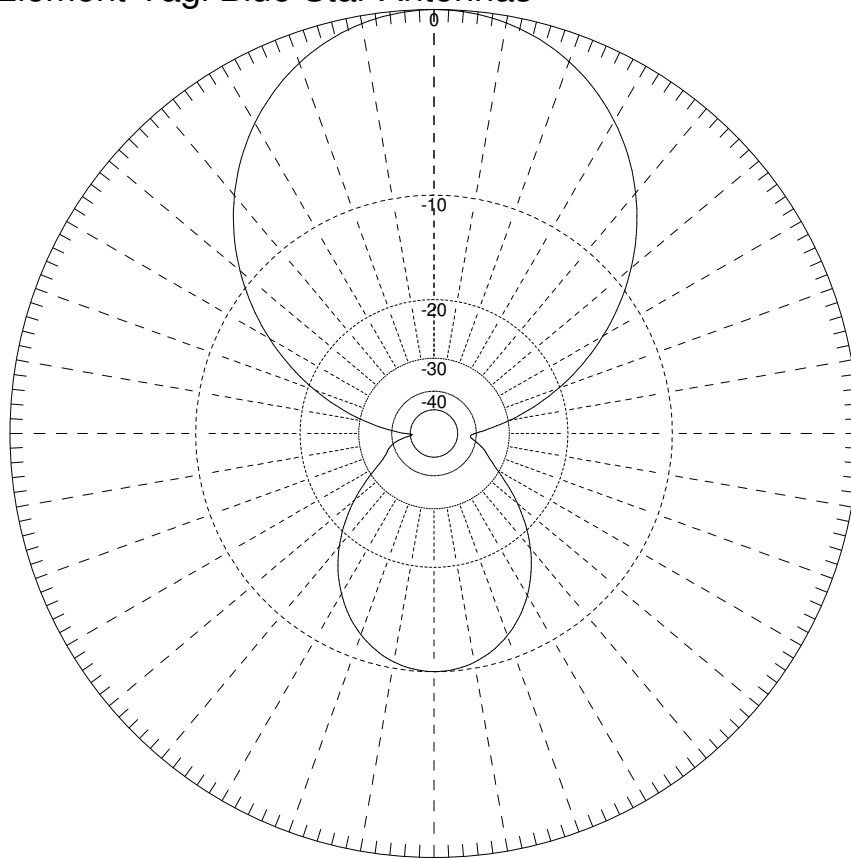

Ga : 13.81 dBi = 0 dB (Horizontal polarization)  
F/B: 10.00 dB; Rear: Azim. 120 dg, Elev. 60 dg  
Freq: 47.500 MHz  
Z: 56.994 - j1.393 Ohm  
SWR: 1.1 (50.0 Ohm), 10.5 (600 Ohm)  
Elev: 17.0 dg (Real GND :5.00 m height)

MMANA-GAL v. 1.1.0.10

47.5 Red Cross 4 Element Yagi Blue Star Antennas

fo: 47.606MHz

